

VUE-2150

15.0" Square Touch Panel Mount Monitor

Preliminary



Features

- 15.0" active screen size (Square)
- Full-flat cover glass for extremely simple surface design
- Built-in multiple I/O interfaces for diverse media connectivity
- Adopts industrial-grade components for guaranteed performance
- Mount with multi-way and easy to extend peripheral devices (box PC/camera...)
- Front IP65 water-proof rating and IK08 high-level impact protection
- Support 10-point touch function (PCAP technology)
- Excellent noise immunity well-suited for rugged applications (CS 10V)
- Support many touch method including fingers, glove, and stylus

Specifications

| | | | | |
|---------------------------------|--------------------------|------------------------|--|-----------------------|
| Brand | | | Advantech | |
| Display | Active Screen Size | | 15.0 inch | |
| | Aspect Ratio | | 4:3 (Square) | |
| | Resolution | | 1024 x 768 (XGA) | |
| | Pixel Pitch | | 0.297(H) x 0.297(W) | |
| | Brightness | | 500nits (Typ.) | |
| | Display Colors | | 16.7M | |
| | Contrast Ratio | | 2500:1 (Typ) | |
| | Viewing Angle | | 176° / 176° | |
| | Response Time | | 13ms (Typ.) | |
| Backlight Life (hours) | | 70,000 (Typ.) | | |
| Touch | Touch Type | | Projected Capacitive Touch (PCAP) | |
| | Touch Function | | 10 points | |
| | Touch Interface | | USB typeB | |
| | Touch Method | | Finger/Glove/Stylus | |
| | Stylus Pen | | Active Stylus (optional accessory) | |
| Connectivity | Input | Video | VGA x 1, HDMI x 1, DisplayPort x 1 | |
| | | Audio | Audio line in x 1 | |
| | | Control | D-SUB-9 x 1 for external Function key | |
| | | Other slots/ports | USB typeB for touch | |
| | Output | Video | N/A | |
| | | Audio | 3W+3W Internal Speaker | |
| Control | | N/A | | |
| System | OSD Language | | English, Simplified Chinese, Traditional Chinese | |
| | OSD Function | | AUTO/UP/DOWN/MENU | |
| Power | Power Type | | External Adapter, AC to DC, 12V | |
| | Power Input-AC | | 100-240Vac, 50-60Hz, 1A | |
| | Power Consumption | | 18W (Typ.) | |
| Environment | Operating | Temperature | -20°C ~ 50°C | |
| | | Humidity | 10% to 85% (non-condensing) | |
| | Storage | Temperature | -20°C ~ 50°C | |
| | | Humidity | 5% to 80% (non-condensing) | |
| Mechanical Specification | Housing Material | | 1.0 mm steel metal (Black), Aluminium bezel | |
| | Waterproof Rating | | Front IP65 | |
| | VESA CompatMBility | | 100 x 100 mm | |
| | Side mount screw hole | | 75 mm for bracket installation | |
| | Hand Hoder/Stand | | Stand (optional accessory) | |
| | Cable Management | | Yes, with cable organizer kit | |
| | Dimensions (W x H x D) | Physical without stand | | 359.1 x 285 x 46.2 mm |
| | | Packing | | 483 x 375 x 195 mm |
| | Weight | Net | | 3.5Kg |
| | | Gross | | 5.5Kg |
| Installation | Installation rotation | | Landscape/Portrait | |
| | Mounting on a wall | | 100 x 100 mm, VESA grid | |
| | Mounting with stand/arm | | 100 x 100 mm, VESA grid | |
| | Mounting through bracket | | 75 mm, Side mount screw hole | |
| | Extending PC/peripherals | | 75 mm, Side mount screw hole | |
| Certificate | | | CB, CE, FCC, BSMI, CCC | |
| Warranty | | | 2-year warranty (1-year for panel) | |

Dimensions

Unit: mm

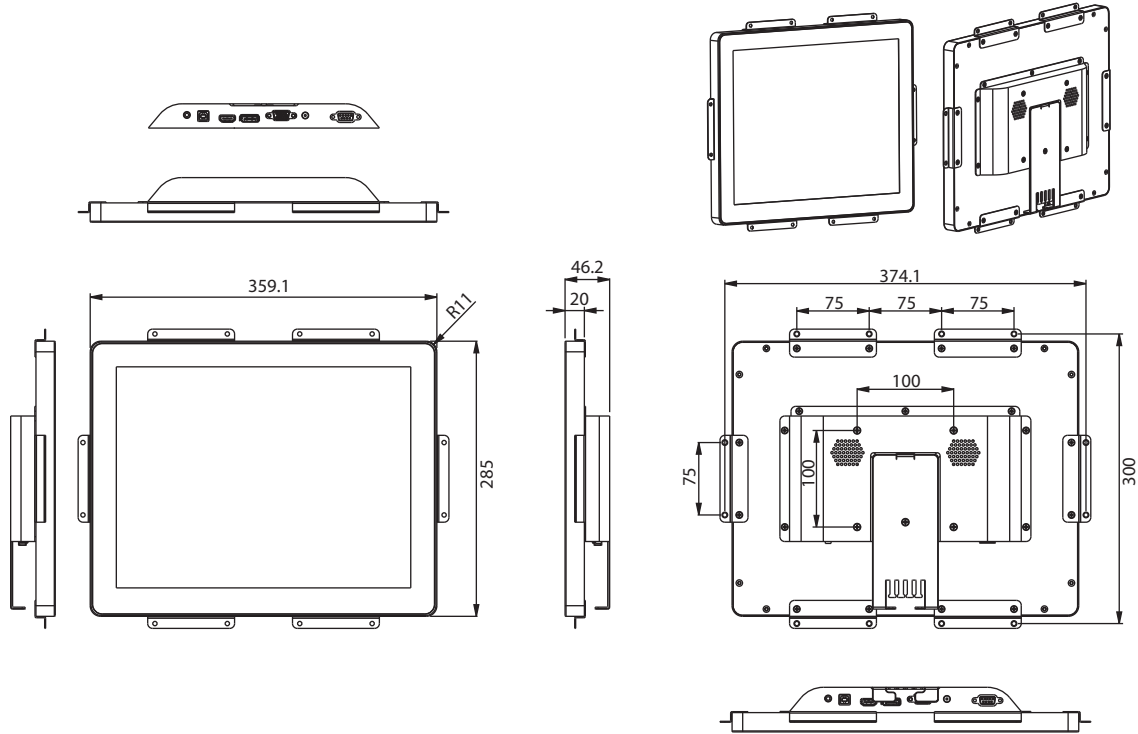

Ordering Information

| Part Number | Description | Packing List |
|--------------------|--|---|
| VUE-2150-XA50PA-N4 | Advantech 15.0" XGA Panel Mount Monitor (incl. Japan and Korea Power Cord) | <ul style="list-style-type: none"> ▪ Power Adapter (1.5M, Black) ▪ Power cord (1.5M, Black) ▪ VGA cable (1.5M, Black) ▪ HDMI cable (1.5M, Black) ▪ DisplayPort cable (1.5M, Black) ▪ Audio cable (1.5M, Black) ▪ USB cable (1.5M, Black), for touch function ▪ External control key pad ▪ Side mount bracket kit (Steel) ▪ Cable organizer kit (Aluminum) ▪ Startup manual (Paper) |
| VUE-2150-XA50PC-N4 | Advantech 15.0" XGA Panel Mount Monitor (incl. China Power Cord) | |
| VUE-2150-XA50PE-N4 | Advantech 15.0" XGA Panel Mount Monitor (incl. Australia, England, Middle East Power Cord) | |
| VUE-2150-XA50PX-N4 | Advantech 15.0" XGA Panel Mount Monitor (incl. Europe, Taiwan, and US Power Cord) | |

Optional Accessories

| Part Number | Description |
|----------------|--|
| 960T-A15DEE-B0 | Active Stylus Pen for VUE-2000 series, Black |